

RICHARD SUMMERLIN MINISTRIES

NOW faith is

JANUARY - FEBRUARY 2024



2024

YEAR OF THE

OBTAINABLE

COMPLETION | FULFILLMENT | ENRICHED

NOW FAITH IS

IN THIS ISSUE

1

THE SUPERNATURAL ABILITY OF FAITH

By: Pastor Richard Summerlin

2

CHURCH OF THYATIRA SEVEN LETTERS TO THE CHURCH

By: Pastor Kimberly Summerlin

3

JUST KEEP RUNNING

By: Angie Thomas

4

CONTINUING IN THE SEASON UNTIL...

By: Dillon Mavrich



EVERYTHING THAT WAS SOWED FOR THAT YOU HAVE NOT REEPEED A HARVEST ON...
EVERY PRAYER THAT HAS NOT BEEN ANSWERED...

WILL BE IN 2024

- PHILIPPIANS 1:6 -

BEING CONFIDENT OF THIS VERY THING, THAT HE WHICH HATH BEGUN A GOOD WORK IN YOU WILL PERFORM IT

- PSALM 115:14 -

THE LORD SHALL INCREASE YOU MORE AND MORE, YOU AND YOUR CHILDREN

- EPHESIANS 3:20 -

NOW UNTO HIM THAT IS ABLE TO DO EXCEEDING ABUNDANTLY ABOVE ALL THAT WE ASK OR THINK

- ISAIAH 55:8-9 -

FOR MY THOUGHTS ARE NOT YOUR THOUGHTS, NEITHER ARE YOUR WAYS MY WAYS, SAITH THE LORD.
FOR AS THE HEAVENS ARE HIGHER THAN THE EARTH, SO ARE MY WAYS HIGHER THAN YOUR WAYS, AND MY THOUGHTS
THAN YOUR THOUGHTS.

CONFESSIO FOR 2024

Say this:

In this year I'm going to obtain every seed I sowed in prior years

I'm going to see the prayers I prayed in previous years
come to pass in 2024

2024 to me is going to be
the year of the open door

2024 to me is going to be the year of access, divine access, grace upon grace in Jesus' name

There is special favor
for me in 2024

Things I could not do in years prior will be done this year

There is an ability; ability that God has set upon me to give me access to the thing that Satan
tried to stop me from having

2024: The Year of More

2024: The Year for Me to Obtain

2024: The Year of Divine Favor

In Jesus' mighty name

I believe it, I receive it
in Jesus' name

Amen

THE SUPERNATURAL ABILITY OF FAITH

BY: PASTOR RICHARD SUMMERLIN

Faith goes beyond our day to day operations. The word supernatural lends the meaning "above natural standards." Supernatural things contain the ability of God. If you remove God from the equation, you remove the supernatural element. Anything that can be done with your own ability is not supernatural. The supernatural is at work when God has to get involved in order for something to become possible.

It is important to know and understand that all faith is supernatural. Many people live their life everyday without faith. It is like people get on the humanity train and just coast through life. Some people only pay attention to their own ability and what they can accomplish on their own. But when you begin to have faith in God, you go beyond your own ability. You bring power from on high down here to earth with you. When there is power available, it is beyond the standard of society and this world.

FAITH IN OPERATION IS SUPERNATURAL AND IS NOW OF GOD'S ABILITY.

You can now begin to place problems, needs, wants and desires in God's hands now. Now that God is involved in it, things are going to begin to happen supernaturally and above the standard for you.

You can think about it this way: placing your hope and faith in God moves the wants, needs, and desires from this world into the realm of the supernatural.

Unbelievers can even be affected by the power of faith when in operation in your life. It could have a negative effect on their life, but they can still be impacted by the ability of faith. God did not say His Words only have an affect on believers. The Bible says when God's Word is sent it will never return back to Him void.

Isaiah 55:11 -

So shall My word be that goes forth from My mouth; It shall not return to Me void, But it shall accomplish what I please, And it shall prosper in the thing for which I sent it.

When you send the Word of God, it doesn't matter if there's demons involved, people under demonic influence involved, counties, cities, nations, kings or queens involved - it does not matter! When faith gets on the scene, it has the ability to change everything around it. No matter what the situation looks like, the Word of God can have an effect on it. Change is inevitable when the Word of God comes on the scene.

Words have a powerful effect on the world around - faith filled words. When you begin to speak words of faith, do not just let the words dribble out of your mouth aimlessly. Your words must have a target and be intentional.

Just like hunting or fishing, there is a plan in place in order to have the most success. You pick a specific area where you will have success and you begin to hunt in that area. You would not go to a gun range and aimlessly fire your weapon and hope that it hits the in-

tended target. It takes setting up and aiming the weapon properly so as to hit the target.

Think about what is opposing you right now. Is it business related? Family related? Health related? Related to finances? Find a fitting word for the situation according to the Word of God, send the Word, with whatever the situation is being your target or your mark, and have an expectation that when the Word hits it, it will bring about change.

WITHOUT FAITH, YOU ARE LIMITED TO YOUR OWN ABILITY.

You are limited to your net worth, to your skill level and to your knowledge. But when you walk into a room, clothed in faith and the royalty to which you have been reborn into, you are now operating on a completely different level.

It would be like you having someone with a higher skill level than you, bigger net worth than you and more knowledgeable than you are walking in and handling a situation for you - this is what it is like with faith. If we were to liken this to a natural man, it would be like having a master negotiator walk into a business meeting with you and having them close the deal for you. But instead of it being a natural man in that meeting, you have the King of Kings coming to sit down at the table with you!

Having faith in God gives you advantages that you could not have without God in the mix. There is an example of this in Mark 5.

Mark 5:1-8

1 Then they came to the other side of the sea, to the country of the Gadarenes. 2 And when He had come out of the boat, immediately there met Him out of the tombs a man with an unclean spirit, 3 who had his dwelling among the tombs; and no one could bind him, not even with chains, 4 because he had often been bound with shackles and chains. And the chains had been pulled apart by him, and the shackles broken in pieces; neither could anyone tame him. 5 And always, night and day, he was in the mountains and in the tombs, crying out and cutting himself with stones. 6 When he saw Jesus from afar, he ran and worshiped Him. 7 And he cried out with a loud voice and said, "What have I to do with You, Jesus, Son of the Most High God? I implore You by God that You do not torment me." 8 For He said to him, "Come out of the man, unclean spirit!"

The Bible says in verse 3 that no one could bind him and again in verse 4 neither could anyone tame him. This man with an unclean spirit was clearly an opposition to humanity. Nothing and no one could stop him. The man with an unclean spirit could be likened to opposition in your life.

Every time you try: opposition. Every time you get ahead: opposition. It seems like every time you do anything in your life there is opposition.

But in verse 6 the supernatural ability of faith begins to work. The man with the unclean spirit looks up and sees Jesus from way off in the distance and runs directly to Him and begins to worship Him.

This is what happens when faith comes on the scene. This is what happens when Jehovah Jireh comes on the scene.

YOUR PROBLEMS BEGIN TO BOW DOWN AND MAKE ROOM FOR THE SUPERNATURAL ABILITY OF FAITH.

Your problems, or you could say your opposition, looks up and sees faith coming from afar off. Your opposition is aware of, acknowledges,

and makes room for faith to take the lead!

Just like the unclean spirits inside of that man flared up when they saw Jesus coming from afar off, the thing that opposes you sees the same thing in you. You have the Holy Spirit residing on the inside of you. You have just as much of God in you with the Holy Ghost as Jesus did when He got out of the boat that day.

The thing that opposes you whether it is mentally, physically, or financially, sees you coming when faith is on your side. There is no difference between the unclean spirits seeing Jesus coming from afar and seeing you with faith coming - He is the same Holy Ghost!

When you send the Word (God's Word), it does not matter who is on the receiving end of the Word - God's Word will always work. The only part for you to play in this transaction is believing.

You must remember, this battle is not natural or in a realm that can be seen with the eyes. If it were something that can be handled in the natural realm, there would not be a need for the supernatural event of faith. The thing that is opposing you may seem out of reach for you but if it were attainable with your own ability, you would not need faith.

God wants to bless you. He does not just deal with your needs only - He will provide your needs but will also take care of your wants and desires.

Say this out loud: God does not only deal with need, He also deals with my want.

He likens His love for you to an earthly father. Doesn't an earthly father love their children and want to give good gifts to them? Your Heavenly Father wants to give you good gifts, too! In Matthew 6, Jesus refers to the birds and flowers and how well God takes care of them. God is willing to provide more for His own children than some fowl and plants, don't you agree?

IT IS TIME WE BEGIN TO BELIEVE BEYOND!

Follow Us on Social Media

Lets Stay Connected



@NewWayChurchFL



Podcast



Facebook



Instagram



YouTube

Church of

SEVEN LETTERS OF THE APOCALYPSE

THYATIRA



BY: PASTOR KIMBERLY SUMMERLIN

JEZEBEL'S CHURCH

And to the angel of the church in Pergamos write; These things saith he which hath the sharp sword with two edges. I know thy works, and where thou dwellest, even where Satan's seat is: and thou holdest fast my name, and hast not denied my faith, even in those days wherein Antipas was my faithful martyr, who was slain among you, where Satan dwelleth. But I have a few things against thee, because thou hast there them that hold the doctrine of Balaam, who taught Balac to cast a stumbling block before the children of Israel, to eat things sacrificed unto idols, and to commit fornication. So hast thou also them that hold the doctrine of the Nicolaitans, which thing I hate. Repent; or else I will come unto thee quickly and will fight against them with the sword of my mouth. He that hath an ear, let him hear what the Spirit saith unto the churches; To him that overcometh will I give to eat of the hidden manna, and will give him a white stone, and in the stone a new name written, which no man knoweth saving he that receiveth it. (Revelation 2:12-17)

Thyatira was the fourth city located on the postal route in Asia Minor and was known for its strong military presence and strong presence of God. It was a blockade city to Pergamum that was home to many politicians and wealthy people.

Jesus did not choose these cities randomly. They were all located in sequence on a road and connected with each other. By addressing these

seven churches in particular, Jesus addressed all the problems in the entire Church that existed at that time. In fact, they are the same problems the Church has been facing for the last 2000 years.

Jesus spoke this to the Church at Thyatira: "And to the angel of the Church in Thyatira write, 'These things says the Son of God, who has eyes like a flame

of fire, and His feet like fine brass: 'I know your works, love, service, faith, and your patience; and as for your works, the last are more than the first. Nevertheless I have a few things against you, because you allow that woman Jezebel, who calls herself a prophetess, to teach and seduce My servants to commit sexual immorality and eat things sacrificed to idols. And I gave her time to repent of her sexual immorality, and she did not re-

pent. Indeed I will cast her into a sick-bed, and those who commit adultery with her into great tribulation, unless they repent of their deeds. I will kill her children with death, and all the churches shall know that I am He who searches the minds and hearts. And I will give to each one of you according to your works. "Now to you I say, and to the rest in Thyatira, as many as do not have this doctrine, who have not known the depths of Satan, as they say, I will put on you no other burden. But hold fast what you have till I come. And he who overcomes, and keeps My works until the end, to him I will give power over the nations— 'He shall rule them with a rod of iron; They shall be dashed to pieces like the potter's vessels'— as I also have received from My Father; and I will give him the morning star. "He who has an ear, let him hear what the Spirit says to the churches."

First, let's look at the word angel in verse 18: "Unto the angel of the church in Thyatira write...." The angel is the Greek word *angelos*, which describes a human messenger or angel, one sent on a special mission, one dispatched to perform a specific assignment, or a delegate or dignitary. Although the word *angelos* can describe a heavenly being, this passage pictures the role of a pastor or a messenger of God.

Angels do not teach or preach the Word of God. It's not their job to bring correction to the Church. That is the calling of those God has called to the fivefold ministry. Pastors are the shepherds of Christ's Church, and when He wants to speak a word of correction to a congregation, He speaks it first to the pastor.

Next, we notice that Christ said to the angel of the Church. He was not talking to or about the physical church building. He was referring to the people. "The word 'church' is the Greek word *ekklesia*, which is a compound of the word *ek*, meaning out, and the word *klesia*, a form of the word *ka-leo*, which means to call. When these

words are joined to form the word *ekklesia*, it describes a called, separated assembly that has been called out from the world for a specific purpose." - Rick Renner

In the pagan world, the word *ekklesia* described a group of citizens called out from the Athenian society to determine law, debate public policy, formulate new policies, argue and rule in judicial matters, and elect chief magistrates. This group was very powerful and had the power to change the atmosphere of their communities.

THE CHURCH HAS BEEN CALLED OUT TO POSITIVELY IMPACT THE ATMOSPHERE OF THE COMMUNITIES IN WHICH THEY LIVE. WE ARE CALLED OUT TO BE REPRESENTATIVES OF GOD IN EVERY TOWN, CITY, STATE, OR NATION.

As mentioned earlier, Thyatira was built by the affluent people of Pergamum to protect themselves from thieves and invaders plundering their treasures. Newcomers arriving in Thyatira for the first time will notice thousands of military tents encircling the city and thousands of armed soldiers moving about.

"In addition to being a military outpost, Thyatira had a thriving commercial trade center. Thyatira developed and became known for its many trade guilds. In fact, it had the most organized trade guilds of all cities throughout the Roman Empire in the First Century.

Trade guilds were much like our unions today. If you were a member, you were virtually guaranteed work; if you were not a member, you couldn't get a job. This dominating influence became a major challenge for believers since trade guilds were saturated with pagan practices.

At the opening of every trade guild meeting, the members would get on their knees and worship the patron god of their organization. Drunkenness, orgies, and debaucheries of all kinds were an integral part of each gathering, and every member was expected to participate.

Believers in Thyatira were faced with a very difficult decision: Remain in the trade guild in order to keep their jobs and earn a living, or honor God with their lives and truly live as the *ekklesia*, the called-out ones. To stay in a trade guild, believers would have to worship foreign gods, as well as participate in all the drunkenness and sexual immorality that came with it. Those who didn't participate in these activities had their membership revoked and were blacklisted from receiving further employment.

These details concerning trade guilds and employment are very important to understand in the light of the message Christ spoke to the Church of Thyatira." -Rick

Renner-

After acknowledging many amazing things the believers were doing right, their charity, service, faith and patience, He issued a strong warning to them because they were allowing a leader in the Church to teach wrong doctrine (vs 20). Jesus urged them to repent and remove her from her position of influence, or He would bring judgment upon them. What Jesus said to the Church at Thyatira still holds true today. People who promote false doctrine or doctrine in error or tolerate those who do must repent to avoid judgment.

Let's look at Revelation 2:20; he said, "Notwithstanding I have a few things against you because you permit that woman Jezebel, who calls herself a prophetess, to teach and to seduce my servants to commit fornication, and to eat things sacrificed to idols."

The word notwithstanding means nonetheless, regardless, or even in spite of all this. So, when Jesus said notwithstanding, we were saying that in spite of all of these good things you have done, there is something I need to deal with.

Then He said, "I have" a few things against you. "I have" means to hold

very personally. So, He was saying the things I'm about to address are very personal and disturbing to me.

"Against" is the next word, and it means a strike against someone. He was saying that despite all the wonderful things you have done, there is an issue we need to deal with. In fact, it is a strike against you that is personally very disturbing to me.

The strike was, according to verse 20, that they permitted that woman Jezebel, who called herself prophetess, to teach and seduce my servants to commit fornication and to eat things sacrificed to idols. No one has said anything or stopped that woman from doing and saying whatever she wanted in the Church.

"Also, notice he said, "that woman." If we look into the two earliest manuscripts of the New Testament, this verse would read a little differently. Instead of "that woman," it would read that woman of yours. In the Greek it means "your wife Jezebel." Remember in the beginning of the article we learned that the letter was written to the pastor of the Church, so He was speaking to the pastor when He said, "that woman of yours." He was referring to the pastor's wife as the very prominent woman in the Church acting like Jezebel."- Rick Renner Christ's Message to Thyatira

Not all pastors' wives are Jezebels, but this one was. This woman calls herself prophetess, which in Greek means prophet. The four postures of a prophet are before, in front of, on behalf of, and in advance. So, a prophet stands before God and listens; he stands in front of people and speaks on behalf of God, and he tells them in advance what will take place. This pastor's wife claiming to be a prophetess; God calls Jezebel. That's definitely not a name I am striving to be called.

The problem was not that she was the pastor's wife and she was teaching. Jesus didn't say that or even mention it. The problem was that she was teaching error and abusing her position of influence. She was the pastor's

wife, and she was seducing (deception or a moral wandering) people, and as a result, they were morally adrift, pictured as a lost animal that cannot find its way home.

She was seducing them to "commit fornication," which is described as any type of sex with another person outside of the bond of marriage. It refers to sexual activity by non-married individuals, including both adultery and homosexuality.

Jezebel was teaching a doctrine of compromise. This doctrine of compromise was the same doctrine the Nicolaitans were teaching in the Church at Ephesus and Pergamum which the Lord dealt with there also. He also called it the doctrine of the Nicolaitans, which I hate. Now, He's dealing with it at Thyatira. Essentially, the doctrine is that it's okay to "lower your standards."

Compromising God's Word diminishes His power, and His people are no longer holy. Our role as a Christian is NEVER to blend in with the world or to do what the world does. Even in Thyatira, where you may not be able to trade to make money to feed your family, God did not allow that as an excuse to compromise. Anyone, even your pastor's wife, who tells you it's okay to compromise is a Jezebel and leading you down a path that leads to destruction. If you are going down a road of compromise, it's time to repent, make things right with Him, and get back on the road to righteousness.

Now is the time. One day soon, it will be too late. When Jesus comes for us and meets us in the sky, it will be too late to repent and make it right. Do it now. Don't compromise. Don't do what the world says to do. Just because some churches are doing it doesn't mean it's scriptural. There are a lot of compromising churches out there. Be careful who you listen to. If it's not in the Bible, it's not for you.

WAYS TO

Give



IN PERSON

MAKES CHECK PAYABLE TO: "NEW WAY CHURCH"
FOR CASH, PLEASE USE ENVELOPE AND INCLUDE YOUR NAME
PLACE ENVELOPES IN OFFERING BAG

ONLINE



NEWWAYCHURCHF.COM/GIVING

PAYPAL



PAYPAL.ME/NEWWAYCHURCHF

TEXT TO GIVE



TEXT [AMOUNT] TO 84321



"GOLIATH HAS FALLEN"

APPAREL AVAILABLE
IN THE FOYER

T-SHIRTS: \$15

HOODIES: \$35

Goliath
FALLEN
has





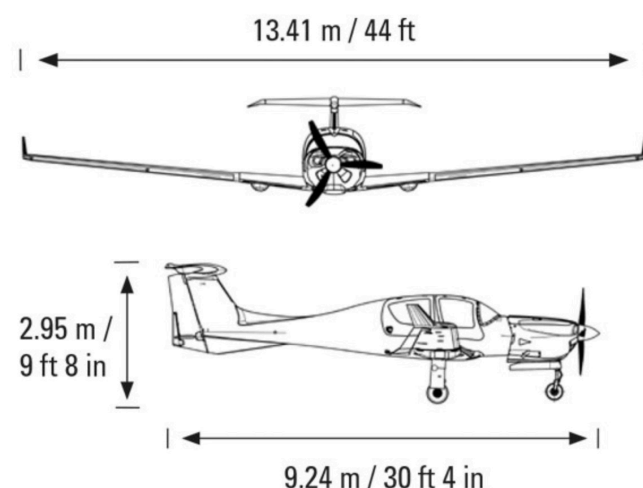

Believe with us

FOR OUR NEW MINISTRY AIRCRAFT “DIAMOND DA50”

DIMENSIONS



SPECS

	9 gal/h		750 nm
	181 kts		5 seats
	20,000 ft		1,232 lbs

MASS & LOADING

Seats	5
Empty weight without options	1,450 kg
Maximum useful load	549 kg
Max. take off mass	1,999 kg
Fuel capacity total (usable fuel)	185 lt / 148 kg



PERFORMANCE

Max. speed (ISA, 16,000 ft, 1,700 kg, MCP)	335 km/h TAS
Cruise speed at 82% (14,000 ft)	319 km/h TAS
Stall speed, landing configuration	107 km/h CAS
Best rate of climb	3.96 m/s
Max. range (FL180, 45% PWR) no climb, no reserves	1,520 km
Max. range incl. 30 min. reserve no climb, no reserves	1,396 km
Consumption at max. range (FL180, 45% PWR)	30.2 lt/hr
Consumption (12,000 ft, 60% PWR)	38.9 lt/hr
Take-off performance (MSL, ground roll / take-off obstacle)	407 m / 734 m
Landing performance (MSL, ground roll / landing distance)	344 m / 678 m

JUST KEEP Running

By: Angie Thomas

**"For I am already being poured out as a drink offering, and the time of my departure has come. I have fought the good fight, I have finished the race, I have kept the faith."
2 Timothy 4:6-7 ESV**

Just for some background context, this is Paul writing to Timothy, his final letter written from a prison in Rome as he was awaiting executed. As we know, Timothy was Paul's son in the faith; and this letter was written to encourage Timothy to stay the course. In this scripture we can see that Paul was echoing through his own life to encourage Timothy to; Fight the Good Fight, Finish the Race and Keep the Faith.

Unfortunately, many of us won't finish our race, because we will get discouraged along the way, "But, as it is written, "What no eye has seen, nor ear heard, nor the heart of man imagined, what God has prepared for those who love him"—" 1 Corinthians 2:9

If you haven't already figured it out, the enemy doesn't want any of us running our race, let alone finishing it! As we press forward with a word from our Pastor, that this is the "Year to Obtain!" In 2024, things are changing for the better for those who will be focused on running their race and not grow weary! "And let us not grow weary of doing good, for in due season we will reap, if we do not give up." Galatians 6:9 ESV

When I think about running a race I'm often reminded of the Prophet Elijah, in 1 Kings 19:10-18, as he's fleeing from Ahab and Jezebel he decides to take up residence in a cave one evening in order to remain in hiding and

ends up having an encounter with God that would alter his race...

1 Kings 19:10-18 "There he went into a cave and spent the night. And the word of the Lord came to him: "What are you doing here, Elijah?" He replied, "I have been very zealous for the Lord God Almighty. The Israelites have rejected your covenant, torn down your altars, and put your prophets to death with the sword. I am the only one left, and now they are trying to kill me too." The Lord said, "Go out and stand on the mountain in the presence of the Lord, for the Lord is about to pass by." Then a great and powerful wind tore the mountains apart and shattered the rocks before the Lord, but the Lord was not in the wind. After the wind there was an earthquake, but the Lord was not in the earthquake. After the earthquake came a fire, but the Lord was not in the fire. And after the fire came a gentle whisper. When Elijah heard it, he pulled his cloak over his face and went out and stood at the mouth of the cave. Then a voice said to him, "What are you doing here, Elijah?" He replied, "I have been very zealous for the Lord God Almighty. The Israelites have rejected your covenant, torn down your altars, and put your prophets to death with the sword. I am the only one left, and now they are trying to kill me too." Also, anoint Jehu son of Nimshi king over Israel, and anoint Elisha son of Shaphat from Abel Meholah to succeed you as prophet. Jehu will put to

death any who escape the sword of Hazael, and Elisha will put to death any who escape the sword of Jehu. Yet I reserve seven thousand in Israel—all whose knees have not bowed down to Baal and whose mouths have not kissed him."

In this passage of scripture, we read that God meets with Elijah, and gives him a renewed focus even as he's fleeing and complaining to ensure he's going to keep running his race with great strength and Fatih! God doesn't appear to him in the wind, nor in the earthquake, or in the fire, but in a gentle whisper! (As a side note, many of us look for God in a great display, but He often speaks in a gentle whisper!)

We can see here the God used these four things to get Elijah back into his race!

- 1.The Lord gives him a fresh instruction, simply by asking, "What are you doing here, Elijah?"
- 2.The Lord once again points Him to his purpose!
- 3.The Lord shows him he's not alone, but there are 7,000 others that have not bowed to Baal or kissed him!
- 4.God lets him know he's not done, his race is not yet finished!

I'd challenge you today, that when the enemy comes and tries to discourage you, and you find yourself fleeing from your purpose; stop and ask, "WHAT AM I DOING HERE?!" I

assure you, you are not the only one living for God! Get back into your purpose and calling! WHY?...
2 Timothy 4:6-7 - You are anointed to run your race!

"Fight the good fight of the faith. Take hold of the eternal life to which you were called when you made your good confession in the presence of many witnesses." 1 Timothy 6:12 NIV

Only those who fight are qualified to win! HOW? "Finally, be strong in the Lord and in the strength of his might. Put on the whole armor of God, that you may be able to stand against the schemes of the devil." Ephesians 6:10-11 ESV

The enemy will use schemes to get you away from your purpose! What are those schemes going to look like? Possibly to only name a few; depression, discouragement, distraction...or sometimes he will plant a person in your life with ill intent to derail you from your race! BE ALERT AND FIGHT!

"Therefore take up the whole armor of God, that you may be able to withstand in the evil day, and having done all, to stand firm. Stand therefore, having fastened on the belt of truth, and having put on the breastplate of righteousness, and, as shoes for your feet, having put on the readiness given by the gospel of peace. In all circumstances take up the shield of faith, with which you can extinguish all the flaming darts of the evil one; and take the helmet of salvation, and the sword of the Spirit, which is the word of God" Ephesians 6:13-17 ESV

Everyone who attended Sunday school has been taught about these weapons, but lets take a different approach when it comes to using these tools more effectively in battle! The Belt of Truth, we know that the truth here is referring to God's Word, but what else does the belt do? A belt holds everything together doesn't it? It's also located around our waist, we must continually fill our bellies with God's Word, because its going to hold everything together! Now, the Shield of Faith; as the enemy throws his darts this is a defensive tool meant to quench darts! And finally, the Sword of the Spirit, again another weapon that uses God's Word! God's Word cuts through the lies of the enemy like a sword! As we continually fill ourselves with God's word both the Shield and Sword become lethal weapons when it comes to running our race! God wants you to have victory and He has thoroughly equipped for you it through His Word! When the devil tries to get you to

quit...tighten your belt, lift your shield, and swing your sword!

When Joshua transitioned to power after Moses death, we can see that God gave him very specific instructions in order to run his race and obtain victory! "Only be strong and very courageous, being careful to do according to all the law that Moses my servant commanded you. Do not turn from it to the right hand or to the left, that you may have good success wherever you go. This Book of the Law shall not depart from your mouth, but you shall meditate on it day and night, so that you may be careful to do according to all that is written in it. For then you will make your way prosperous, and then you will have good success." Joshua 1:7-8 ESV

Again we see here that God gives fresh instructions for Joshua (just like he did for Elijah), points him to his purpose, and gives him even more instruction to set him up for victory by telling him to meditate on God's Word day and night!

- 1.This Book of the Law shall not depart from your mouth
-MOUTH (keep the Word of God in your mouth all times)
- 2.You shall meditate on it day and night
-MIND (keep God's truth in your thoughts - take every thought captive)
- 3.Do according to all that is written in it
-MANIFEST (Obey God's Word and His instructions - obedience brings blessings and victory)

The moment you received salvation, you transitioned from who you used to be, to what God has called you to be! As you run your race, expect to have victory! 2024, is your "Year to Obtain!"

"Whoever makes a practice of sinning is of the devil, for the devil has been sinning from the beginning. The reason the Son of God appeared was to destroy the works of the devil." 1 John 3:8 ESV



Continuing In The Season Until...

By: Dillon Mavrich

The Bible clearly explains to us that there are seasons here on earth. Just like a calendar year on earth contains 4 major seasons, spring, summer, fall and winter, so does your and my life contain seasons that come and go. Take the great king Solomon's words out of the book of Ecclesiastes:

Ecclesiastes 3:1-8

1 To everything there is a season, and a time for every matter or purpose under heaven:

2 A time to be born and a time to die, a time to plant and a time to pluck up what is planted,

3 A time to kill and a time to heal, a time to break down and a time to build up,

4 A time to weep and a time to laugh, a time to mourn and a time to dance,

5 A time to cast away stones and a time to gather stones together, a time to embrace and a time to refrain from embracing,

6 A time to get and a time to lose, a time to keep and a time to cast away,

7 A time to rend and a time to sew, a time to keep silence and a time to speak,

8 A time to love and a time to hate, a time for war and a time for peace.

It should comfort you to know that every event in your life is temporary. That means it is subject to change. Good and bad, things are subject to change. Solomon is saying in verse 6 "...a time to get and a time to lose..." there has to be a break in losing... but with 'getting' there is a temporary exposure to loss at some point. If we know this ahead of time, in my opinion, it would make sense to make preparation for the 'losing' seasons while in your 'getting' seasons.

One thing is clear though: it is unnecessary to know the length of the season we are currently in. In fact, trying to figure out how long a season will last will bring all sorts of mixed feelings and emotions into your life. It is not your job to know how long a particular season in your life will last. This type of thinking actually will breed frustration - because you will never have an answer for the deadline of a season. That is because there is no faith in having the end date in mind.

Not knowing the length of something and casting off the care of what the end date is allows you to focus without wavering. If you know the length of the season and when it will specifically end, you can grow weary knowing how far out you are. But if you believe every day is the day the Lord has made, FOR YOU, there comes an attitude of expectation and faith!

Jesus said you would have an idea of when that next season is coming - just not the exact moment in time. Take His return for example. The Bible teaches us that there will be a season in time where Jesus returns to this earth - but no man knows the day or the hour. However Jesus tells us we will know we are coming upon this day "...when you see all these things, know that it is near..." in other words, you'll know Jesus is coming by what is happening around you.

Matthew 24:32-34

32 From the fig tree learn this lesson: as soon as its young shoots become soft and tender and it puts out its leaves, you know of a surety that summer is near.

33 So also when you see these signs, all taken together, coming to pass, you may know of a surety that He is

near, at the very doors.

34 Truly I tell you, this generation (the whole multitude of people living at the same time, in a definite, given period) will not pass away till all these things taken together take place.

You'll begin to recognize what season you are in and what season is coming based upon what you are seeing happen around you.

Let me encourage you to do this one thing: be a participant in whatever season you are currently in. God has called you to a higher level in life - no matter what level you are at currently. There is always a higher level.

So be heavily involved in the current season you are in. Our Pastor has taught us: the way you leave one season is the way you enter into the next season. God's expectation of His children is to reach the potential He has placed within them and not get lazy in the process of it.

Hebrews 6:9-12

9 Even though we speak this way, yet in your case, beloved, we are now firmly convinced of better things that are near to salvation and accompany it.

10 For God is not unrighteous to forget or overlook your labor and the love which you have shown for His name's sake in ministering to the needs of the saints (His own consecrated people), as you still do.

11 But we do [strongly and earnestly] desire for each of you to show the same diligence and sincerity [all the way through] in realizing and enjoying the full assurance and development of [your] hope until the end,

12 In order that you may not grow disinterested and become [spiritual] sluggards, but imitators, behaving

as do those who through faith (by their leaning of the entire personality on God in Christ in absolute trust and confidence in His power, wisdom, and goodness) and by practice of patient endurance and waiting are [now] inheriting the promises.

Pay attention closely to what the author of Hebrews is saying to us in verse 11 and 12: to be diligent to develop and avoid growing disinterested by becoming sluggards - or lazy.

Be the best you can - be the best YOU that you can be. Peace comes from faithfulness. Joy comes from faithfulness. To paraphrase a long story in Matthew, Jesus tells the story about a traveling man who had servants. This man was leaving town and gave some money to three of his servants to take care of. One takes his portion, protects it, grows it and returns his portion to the master - doubled. The traveling man replies to his servant this way:

Matthew 25:21

21 'Well done, good and faithful servant; you were faithful over a few things, I will make you ruler over many things. Enter into the joy of your lord.'

Enter into the joy of your lord. Joy comes from faithful-

ness. Peace comes from faithfulness. But when you are not faithful with what God has given you and you are too busy looking around for the next season or the next best thing, not only do you not produce the outcome that God intends you to produce, but you also create stress for yourself.

Stress comes from knowing something needs to get done and it is not getting done.

Whether it is your ability or not, stress comes from having your attention on the wrong thing. Like we talked about earlier, knowing when or how something is going to happen is none of your business or concern. God is the one that changes the season - it is your job to remain faithful and to continue within that season.

Focus is the key ingredient here to staying within the joy of the Lord - but not just focus alone, focus and attention on the right things.

Matthe 6:31 & 33

31 "Therefore do not worry..."

33 But seek first the kingdom of God and His righteousness, and all these things shall be added to you..."

Your attention on when will this season end or when will the next season begin does not make either thing happen faster. It just puts you in a spot of anxiety and stress. You should be focusing on the Kingdom instead of focusing on the need.

God does the adding - you do the faithing.



The
RICHARD
SUMMERLIN
Podcast

EVERY TUESDAY
0900AM

www.youtube.com/newwaychurchfl

**GO
ING
HIGHER**

New Way Church



RSM

RICHARD SUMMERLIN
MINISTRIES

